

MWX65

User manual & Installation guide

All-in-one wall panel



www.audac.eu

Index

Introduction	5
Precautions	6
Chapter 1: Overview of MWX65	8
Overview front panel	8
Front panel description	9
Overview rear panel	11
Chapter 2: Quick start guide	12
Chapter 3: Installing, connecting & configuring	14
Installing	14
Connecting	15
Configuring	18
Chapter 4: Using the MWX65	21
Chapter 5: Technical specifications	25
Chapter 6: Notes	27

Introduction

All-in-one wall panel

The MWX65 is an All-in-one wall panel designed for use in combination with AUDAC MTX series matrix systems. This wall panel has a graphic display and can control the routing, volume, bass, treble and mute for one zone. Besides those control functions, it also provides the possibility to connect a microphone and a stereo line input source. The MWX65 wall panel should be connected using UTP/FTP CAT5E (or better) twisted pair cabling.

The following functions of the zone can be controlled:

- Volume within a range of 0dB to –70 dB
- Input source selection
- Mute / unmute
- Bass within a range of –14dB to +14dB
- Treble within a range of –14dB to +14dB

The microphone input on the wall panel is connected using an XLR connector, while the line inputs are implemented using RCA connectors.

Precautions

READ FOLLOWING INSTRUCTIONS FOR YOUR OWN SAFETY

ALWAYS KEEP THESE INSTRUCTIONS. NEVER THROW THEM AWAY

ALWAYS HANDLE THIS UNIT WITH CARE

HEED ALL WARNINGS

FOLLOW ALL INSTRUCTIONS

NEVER EXPOSE THIS EQUIPMENT TO RAIN, MOISTURE, ANY DRIPPING OR SPLASHING LIQUID.

DO NOT INSTALL THIS UNIT NEAR ANY HEAT SOURCES SUCH AS RADIATORS OR OTHER APPARATUS THAT PRODUCE HEAT

DO NOT PLACE THIS UNIT IN ENVIRONMENTS WHICH CONTAIN HIGH LEVELS OF DUST, HEAT, MOISTURE OR VIBRATION

THIS UNIT IS DEVELOPED FOR INDOOR USE ONLY. DO NOT USE IT OUTDOORS

ONLY USE ATTACHMENTS & ACCESSORIES SPECIFIED BY THE MANUFACTURER

DON'T MAKE OR CHANGE ANY CONNECTIONS WHILE THE UNIT OR ANY ASSOCIATED DEVICES ARE POWERED ON.



CAUTION – SERVICING

This product contains no user serviceable parts. Refer all servicing to qualified service personnel. Do not perform any servicing (unless you are qualified to)



EC DECLARATION OF CONFORMITY

This product conforms to all the essential requirements and further relevant specifications described in following directives: 2014/30/EU (EMC), 2014/35/EU (LVD) and 2011/65/EC (RoHS)



WASTE ELECTRICAL AND ELECTRONIC EQUIPMENT (WEEE)

The WEEE marking indicates that this product should not be disposed with regular household waste at the end of its working life. This regulation is created to prevent any possible harm to the environment or human health.

This product is developed and manufactured with high quality materials and components which can be recycled and/or reused. Please dispose of this product at your local collection point or recycling centre for electrical and electronic waste. Do this to make sure that the product is recycled in an environmental friendly way, and help to protect the environment in which we all live.

Chapter 1

Overview front panel

The front panel of the MWX65 wall panel contains a 2.5" graphic color LCD display with two additional audio inputs. The unbalanced line input is connected with RCA connectors while an XLR connector is used for connecting balanced microphones. Each input is accommodated with a push-lock gain control potentiometer and a clip indicator LED. A big rotatable function selection push dial is provided below the LCD display.

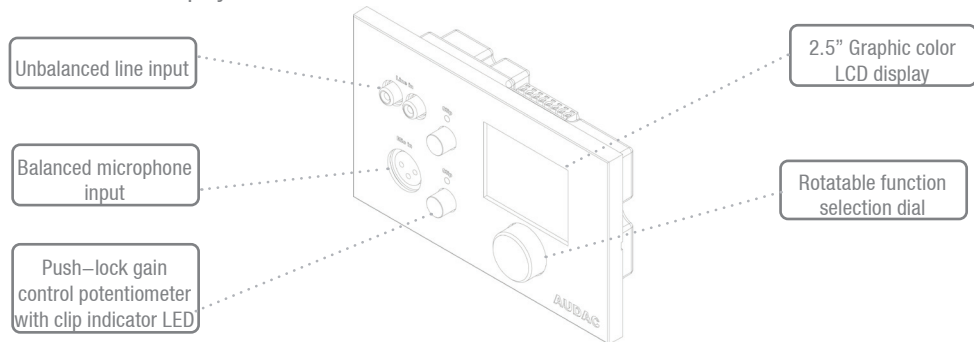

Front panel description

Unbalanced line input

An unbalanced stereo audio source can be connected to these RCA connectors, creating an additional local input.

Push–lock gain control potentiometer with clipping LED

The sensitivity for the line and microphone inputs can be adjusted with these potentiometers. Through the push–lock mechanism, they can be opened and hidden again by pressing them. Above every potentiometer is a clipping indicator LED provided which illuminates when clipping of the input signal occurs. When this LED is lit, the signal is distorted and the level should be reduced by turning back the potentiometer. The sensitivity for the line and microphone input can be adjusted within a range of 0dB and $-\infty$ dB.

Balanced microphone input

A microphone can be connected to this XLR input connector, which allows voice announcements to a particular zone. For powering condenser microphones, a phantom power voltage of 12 Volts can be software enabled.

2.5" Graphic color LCD display

This graphical color LCD displays gives a clear overview of all the functions and settings of the wall panel.

Rotatable function selection dial

The big rotatable dial enables you to control all functions and settings of the wall panel by just three simple actions: rotate left, rotate right and push. Actions such as browsing between the zones, increasing the volume, audio source selection, ... can be done by rotating the dial left and right. Actions such as selection and deselection, toggle settings, ... can be done by pressing the knob.

Overview rear panel

The rear panel of the MWX65 contains an 8 pin connector for connecting the wall panel to the matrix system and a jumper for terminating the RS485 databus. A detailed description of how the MWX65 should be connected, can be found in the chapter 3 of this user manual. The jumper for terminating the databus should always be placed when only one wall panel is connected to the databus, and is always provided and placed upon delivery.

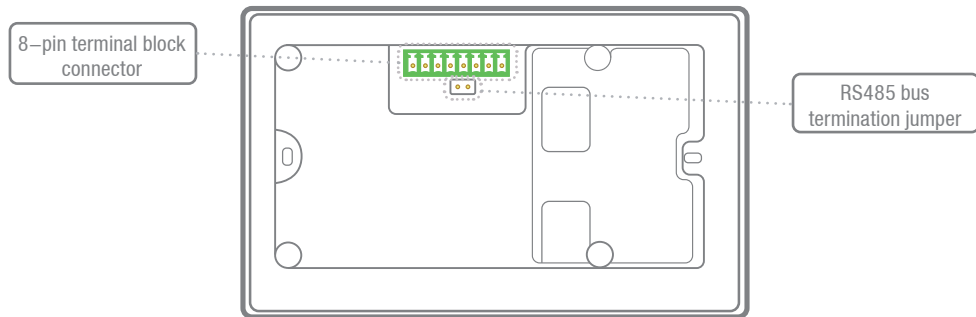

Chapter 2

Quick start guide

This chapter guides you through the setup process for a basic project where a MWX65 wall panel should be connected to an MTX series audio matrix. Make sure the audio matrix is installed correctly and is powered off when connecting the MWX65 wall panel.



ATTENTION

Making or changing any connections while powered—on can lead to permanent damage of the equipment. Make sure the power is switched off while connecting and verify correct connection method before powering on!

Connect the MWX65 wall panel to the matrix system with a twisted pair CAT5E (or better) cabling with a maximum cable length of 300 meters. Make sure the MWX65 is connected to one of the wall panel inputs on the rear side of the MTX. It should be patched to the input of the zone where the local audio input should be linked to. Go to the setup menu in the web based interface of the MTX and go to system configuration. Click on MWX65 for making the settings.

An unique address should be selected for every connected wall panel. The address for a wall panel always starts with the letter “W”. When only one wall panel is connected, the most logical way is to start with address “W001”, and increase the address number for every subsequent wall panel. (“W002” for wall panel 2, “W003” for wall panel 3, ...)

After the desired address is selected, click the “Set address” button. A message will start blinking on all the MWX65 wall panels connected in your system. When the function selection dial on the wall panel is pressed, the selected address will be assigned to the corresponding wall panel.

Now the zone, which should be controlled and the selectable inputs need to be selected. The zone can be selected by the dropdown list

This can be done in the user interface with the two dropdown lists. When the zone or input is selected, it automatically appears inside the listbox. To remove a zone or input from the listbox, select the desired zone or input in the listbox, and click the “Remove Zone” or “Remove Input” button.

Next to the listboxes you can find several selection & checkboxes whereby some presets / restrictions can be made to the corresponding wall panel. After the settings are made, click the “Save to Wallpanel” button on the bottom of the window, and your changes will be uploaded to the wall panel.

Your wallpanel is now ready for operation.

Chapter 3

Installing, connecting & configuring

Installing

Different kinds of installation boxes are available for the MWX65, making both flush and surface mount installation possible on different kinds of surfaces. The WB50/FG installation box allows flush mount installation in any kind of hollow wall such as gypsum, wood or any other material with a plate thickness between 7 mm and 25 mm. The WB50/FS installation box allows flush mount installation through mortar in stone or concrete surfaces. For surface mount installation, wall boxes WB50/B and WB50/W are available.

The wall panel should be fixed into the installation box by tightening the included screws.

Connecting

The MWX65 wall panels should be connected on the WP (wall panel) ports of the matrix system with an UTP CAT5E (or better) twisted pair cable according to the TIA/EIA T568B standard. Depending of the used matrix system (MTX48 or MTX88) 8 or 16 Wall Panel (WP) inputs are available, Two for each zone. Make sure the MWX65 wall panels are connected to the right zone whereto the audio inputs should be linked.

Below is the cable connections when using one MWX65 on a single wall panel input.

MWX65 Port PINOUT (RS485, Balanced Analog Audio, +24V DC):

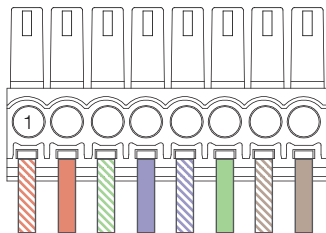
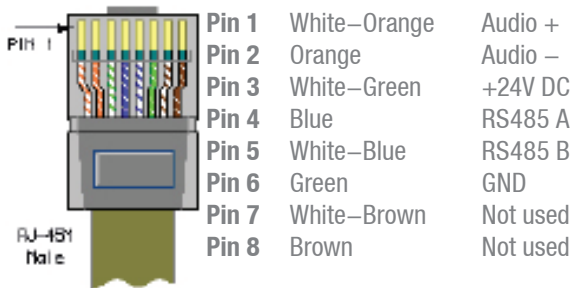

Below is the cable connections when using two MWX65 units on a single wall panel input using a single CAT5e cable.

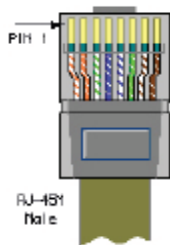

First MWX65 connector PINOUT

Pin 1	White-Orange	Audio 1 +
Pin 2	Orange	Audio 1 -
Pin 3	White-Green	+24V DC
Pin 4	Blue	RS485 A
Pin 5	White-Blue	RS485 B
Pin 6	Green	GND
Pin 7	White-Brown	(Audio 2 +)
Pin 8	Brown	(Audio 2 -)

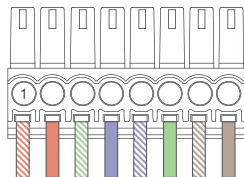

Second MWX65 connector PINOUT

Pin 1	Brown	Audio 2 +
Pin 2	White-Brown	Audio 2 -
Pin 3	White-Green	+24V DC
Pin 4	Blue	RS485 A
Pin 5	White-Blue	RS485 B
Pin 6	Green	GND
Pin 7	White-Orange	(Audio 1 +)
Pin 8	Orange	(Audio 1 -)

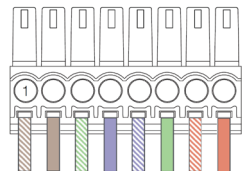

ATTENTION

Making or changing any connections while powered-on can lead to permanent damage of the equipment. Make sure the power is switched off while connecting and verify correct connection method before powering on!-

Connection possibilities

Connections which WORK



Multiple MWX45 and one MWX65 Wall panel connected to one Wall Panel Input



Multiple wall panels with audio input and multiple MWX45 on one WP port
One WLI / MWX65 and one WMI



Two pcs MWX65 and multiple MWX45

Connections which DON'T WORK



Multiple wall panels with audio input on one WP port
One MWX65, one WLI and one WMI

Configuring

Before the MWX65 can be made operational, the following configurations should be made. First of all, an address needs to be assigned and the available inputs need to be defined.

Configuration can be made by following next steps:

1) Click on “Setup” (top right hand corner of the webinterface then “System configuration”). There you choose “MWX65”. A window is shown where all the configuration settings for the MWX65 can be made. On the left side, a dropdown list is visible whereby the address for the MWX65 can be selected. The addresses can be selected between “W001” to “W008”. After the desired address is selected, click the “Set Address” button and the displays on all the MWX65 will start blinking. Confirm the address of the wall panel by pushing the big rotary button on the wall panel and the selected address will be assigned to the wall panel.

2) The zone which should be controlled by this wall panel can be selected in the dropdown list which is shown one position to the right.

3) The inputs which are selectable with the wall panel can be chosen in the “Selectable inputs” dropdown list. After the inputs are selected, they will appear in the listbox shown below. They can be removed again from this listbox by selecting them, and clicking the “Remove Input” button.

4) Certain actions such as Volume Change, Input change, Mute, Tone control and settings can be disabled from the wall panel by checking the checkboxes.

5) The microphone input has the possibility to provide +12V phantom power for powering condenser microphones. The phantom power can be switched ON and OFF by clicking the “Enable Mic Phantom” checkbox. This setting can also be changed in the MWX65 settings menu. (If “Block settings menu” isn’t checked)

6) The Backlight level, screensaver and screensaver delay can be set by means of three dropdown boxes. This setting can also be changed in the MWX65 settings menu. (If “Block settings menu” isn’t checked)

7) When the settings are made, press the “Save to Wallpanel” button and the settings will be send to the selected MWX65 wall panel.

Previously made settings can be retrieved from the wall panel by clicking the “Load from Wallpanel” button. Hereby, the settings which are stored in the wall panel will be displayed in this window, making it possible to make any changes to the current settings.

Chapter 4

Using the MWX65

When the MWX65 is correctly installed, connected and configured, the wall panel is ready to be operated. The standard screen of the MWX65 gives an overview of all the functions. These can be controlled by means of the MWX65 wall panel for the corresponding zone.

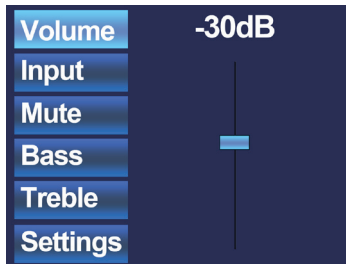

The main screen provides an overview of the functions which can be controlled for the zone it is connected and configured to. Settings such as Volume control, Input signal selection, Mute and Tone control can be made for the corresponding zone. On the left side of the display are all the possible settings displayed, and scrolling between the settings can be done by rotating the selection dial. The settings will illuminate one by one, when rotating the dial.

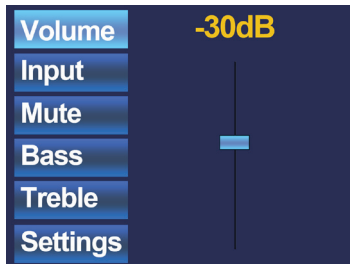

When the desired setting is selected, you can change it by pushing the dial. For example, when Volume is selected, the attenuation on top of the fader will illuminate and the volume can be changed by rotating the dial. When the volume is set to the desired level, press the dial again for scrolling between the settings. You can select the input source by rotating the dial till 'Input' illuminates.

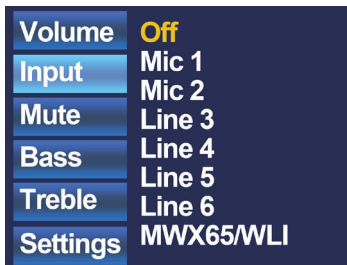

When 'Input' is lit, you can push this button and you will be redirected to the input selection window. This window shows all (configured) input channels which can be selected. You can scroll through the inputs by rotating the selection dial, and the desired input can be selected by pushing the dial.

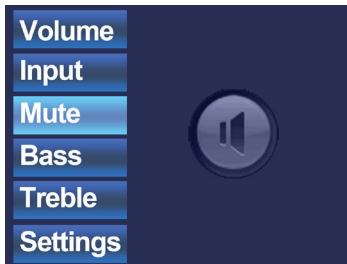

When the input selection is made, you can scroll further through the menu and make other changes such as muting, and changing the tone control. When the zone should be muted, just scroll to the 'Mute button' and push the selection dial. When the selection dial is pushed, you can toggle between 'Mute' and 'Unmute'.

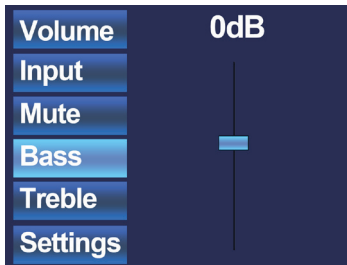

The other settings which can be changed to the zone is the two band tone control. The tone control can be activated by selecting the 'Bass' and 'Treble' buttons, and the adjustment of the tone control works with a fader just as the volume control. You can increase and decrease the high and low tones the same way as adjusting the volume, by simply rotating the selection dial. The Bass and Treble both can be adjusted between the ranges of +14dB and -14dB.

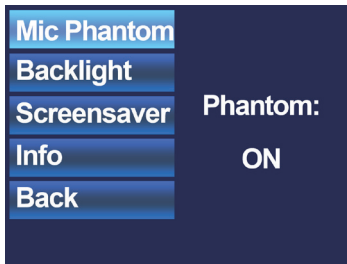

The latest button shown on the main screen is 'Settings'. When this button is clicked, you will be redirected to the settings window. In this window, settings such as phantom power enabling, backlight settings and screensaver settings can be made.

With the option 'Mic Phantom', the 12V DC phantom power to the microphone input on the wall panel can be enabled and disabled. The 'Backlight' option enables you to adjust the backlight intensity for the LCD display and with the 'Screensaver' option the desired time before the screensaver shows up can be set. Info shows some more information about the wallpanel and the current software version.

When all the settings are set to the desired value, click 'Back' to return back to the main screen.

Chapter 5

Technical Specifications

System specifications:

Control		RS-485
Audio transfer		Mixed Analogue differential (Dual mono)
Inputs		
Unbalanced Stereo	Connector	RCA
	Sensitivity (1W/1m)	-12 dBV ~ +12 dBV
	THD+N (@ 1 kHz)	< 0.05%
	Signal / Noise	85 dB
Balanced Microphone	Connector	XLR female
	Sensitivity (1W/1m)	-50 dBV ~ -15 dBV
	THD+N (@ 1 kHz)	< 0.1 %
	Signal / Noise	75 dB
Phantom Power		12 V DC (software enabling)
Cabling CAT5		(up to 300 meter)

Display	Type	2.5" Graphical Full colour
Power	Consumption	1.8 W – 75 mA / 24V
Connectors		8–pin Euro Terminal Block

Product Features:

Dimensions	153 x 94 x 45 mm (W x H x D)
Built–in depth	37 mm
Weight	0.210 kg
Construction	ABS
Colours Black	(RAL9005) (MWX65/B)
White	(RAL9010) (WMX65/W)
Optional accessories	WB50 Surface mount installation box (/B or /W) WB50/FG Flush mount installation box for hollow wall WB50/FS Flush mount installation box for stone/concrete wall

Chapter 6

Notes
